

1. Scope

This document describes the product specification and using condition of the Lithium-ion Polymer rechargeable cell

2. Product

2.1 Name : Lithium-ion polymer rechargeable cell

3. Specification /产品规格

Item 项目	Specification 规格		
3.1 Nominal voltage 标称电压	3.7	V	
3.2 Minimal capacity 最小容量	1050	mAh	discharge from 4.2V to 3.0V at 0.2C mA 由 4.2V放电至3.0V截止, 放电电流0.2CmA
3.3 Initial impedance 电池内阻	≤ 200	mΩ	The Specifications included cell;PCM;wire 此参数包含电芯、保护板、导线
3.4 Full charge voltage 满充电压	4.20±0.05	V	
3.5 Pack Voltage 出货电压	3.7~3.9V	V	As of shipment. 出厂时的电压
3.6 Max charge current 最大充电电流	1050	mA	电芯允许充电电流
3.7 Charging method 充电方式	CC/ CV 恒流/恒压		charge with constant current 0.5C to 4.2V, then charge with constant voltage 4.2V till charge current is less than 0.01C 先0.5C恒流充电至4.2V, 然后恒压充电 至电流小于0.01C
3.8 Max discharge current 最大放电电流	2100	mA	电芯允许放电电流
3.9 Discharge cut-off voltage 放电截止电压	2.40	V	PCM cut-off voltage 保护板截止电压
3.10 Operating environment: 工作环境	Charging 充电 Discharging 放电		0°C ~ 45°C ; 65±20%RH -10°C~60°C ; 65±20%RH
3.11 Storage environment 储存环境	-10°C~45°C 65±20%RH		storage for a long time(≥3months) and the storage condition shall be: ≤45°C; 65±20%RH; 3.7~3.9V 长时间储存 (不小于3个月), 储存条件是: ≤45°C; 65±20%RH; 3.7~3.9V
3.12 Pack Weight (Approx) 大约重量	23.0	g	

4. Outward appearance and Dimension /外型 and 物理尺寸

单位: mm

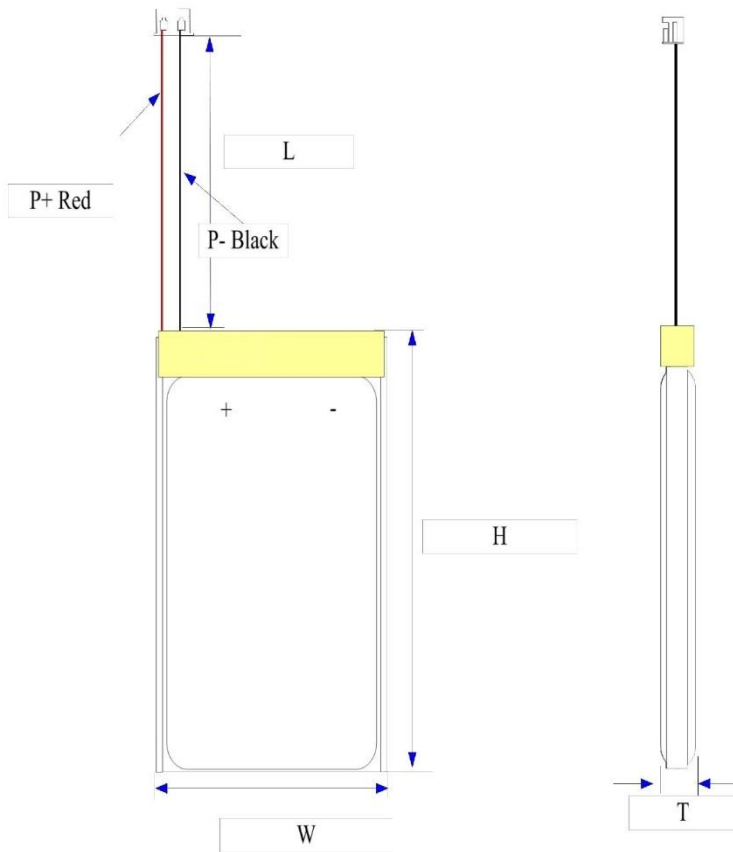

项目	尺寸
电池厚T	Max: 6.2
电池宽W	Max: 34.5
电池高H	Max: 52.0
线长L	100±2
剥线L1	3±1
折边方式	单折边

Basis BOM List/基本BOM表

Item 序号	Reference 名称	Material name 规格	Model/Specification 描述	Quantity 用量	Remark 备注
1	Cell 电芯	603450	3.7V 1050 mA h	1	
2	PCM 保护板	ZN-Pcm	ZN-Pcm	1	
3	Red wire 红线	UL1007 24#	Red	1	
4	Black wire 黑线	UL1007 24#	Black	1	
5	Connector 端子	2pin JST-PH	/	1	

5. PCM/保护板参数

Symbol (符号)	Name (名称)	MIN (最小值)	Typical. (典型值)	Max (最大值)	Unit (单位)
VDET1	Over-Charge detect voltage (过充电保护电压)	4.18	4.23	4.31	V
VDET2	Over-discharge detect voltage	2.30	2.40	2.50	V
IEC	Excess Current threshold (最大过流值)	1.2	1.3	1.6	A
IDD	Supply current (自耗电电流)	5	4	7	μA
RD	Internal resistance in normal operation (导通内阻)	---	---	70	mΩ
RWV	Reverse withstand voltage: reverse voltage adding to pack caused by load circuit				V
RWI	Reverse current adding to pack caused by load circuit (反向耐电流: 负载线路产生的, 反加在组合电芯上的电流): Max.5				A

6. Schematic diagram(原理图)

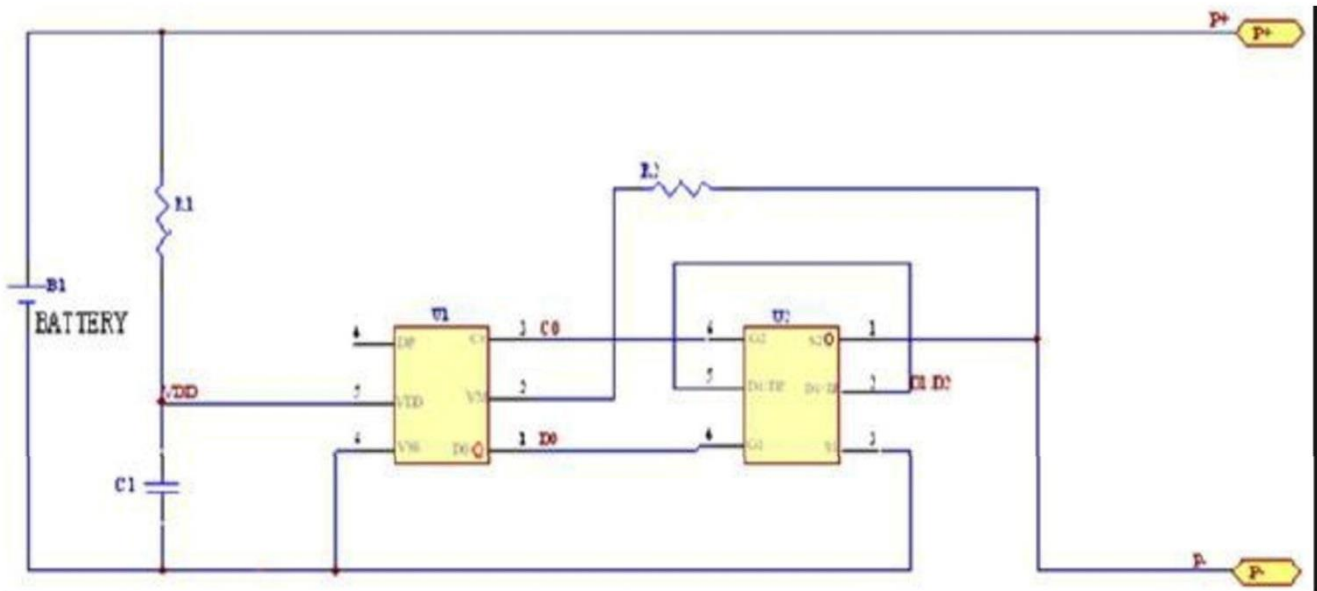

6. Visual Inspection/外观

There shall be no such defect as scratch,flaw,crack,and leakage,which may adversely affect commercial value of the product.
不允许有任何影响电芯性能的外观缺陷，如裂纹、裂缝、泄漏等。

7. Cell Specification/电芯规格

7.1 Electrical characteristics

电气特性

Items	Test Method and Condition				Criteria
7.1.1 Full charge 满充电	charge to 4.2V with 0.5C ,then go on charging with constant voltage 4.2V till charge current declines to 0.01C . 以0.5电流恒流充电至4.2V，然后4.2V恒压充电至电流小于0.01C				/
7.1.2 Initial capacity 初始容量	The capacity means the discharge capacity of the cell that was discharged to 3.0V with discharge current of 0.2C within one hour after the full charge. 容量,即指在电池满充电后1小时内用0.2C电流放电,放电至3.0V截止的放电容量				\geq 1050 mAh
7.1.3 Cycle life 循环寿命	Cycle life is the capacity of the cell that was repeated 300 cycles with full charge and then discharging to 3.0V with discharge current of 0.2C . 测量电池满充电后以0.2C放至3.0V，充放电循环300次后的放电容量。				\geq 80% Initial capacity
7.1.4 Initial impedance 内阻	Cell resistance was measured at AC 1KHz after 50% charge and the test temperature was 25°C . 半充电状态，在1kHz下测量电池内部阻抗。测试温度为室温（25°C）				\leq 200 mΩ
7.1.5 Temperature Capacity Test 温度性能	The Temperature Capacity Test is the discharging ability at 0.2C of the cell in different temperature as follow after fully charged in a temperature of 25°C,the time between charging and discharging must beyond 3 hours. 不同温度条件下的放电容量对比，即在25°C常温条件下电池满充电后，在下表所示温度下以0.2C放至3.0V的容量。如果充电和放电温度不是同一温度时，温度变化的间隔时间要求是3小时。				
	Charge temperature 充电温度		Discharge temperature 放电温度		
	25°C		-10°C \geq 70%	0°C \geq 80%	25°C 100%
7.1.6 Self-discharge 自放电	After the full charging, storage the cells in a temperature of 25°C for 28 days, then measure the capacity with discharge current of 0.2C till 3.0V. 满充电后在25°C下储存28天,检测0.2C放电至3.0V的容量。				Capacity \geq 80% Initial capacity
7.1.7 store 存放	At 50% SOC and specified temperature, recoverable capacity in % vs. time 电池在50%的荷电态下在以下的条件下存放恢复容量-时间				
	-10°C to 30°C 12months	30°C to 45°C 3months	45°C to 60°C 1month	60°C to 70°C 4hr	
	\geq 85%	\geq 85%	\geq 60%	\geq 80%	

7.2 Mechanical specification

机械特性

Items	Test Method and Condition	Criteria
7.2.1 Vibration Test 振动	Fixed the fully charged cell to vibration table and subjected to vibration cycling that the frequency is to be varied at the rate of 1Hz per minute between 10Hz and 55Hz, the excursion of the vibration is 0.8mm. The cell shall be vibrated for 90 ~100 minutes per axis of XYZ axes. 电池按照振幅为0.8mm的谐振形式进行振动。振动频率在10和55Hz间以1Hz / min的速率变化，往复振动90 ~ 100min。电池应该在互相垂直的三个面进行测试。	No explosion No fire, No leakage. 电池不爆炸，不起火，不漏液
7.2.2 Drop Test 跌落	The cell is to be dropped onto concrete ground from a height of 1.2 meter three times . 电池从1.2m高处自由落下测试3个循环	No explosion, No fire 电池不爆炸，不起火

7.3 Safety 安全测试

Items	Test Method and Condition	Criteria
7.3.1 Crush Test 挤压	The pressure on the surface of the fully charged cell do not stop being raised until 17.2 Mpa when the cell is crushed by two flat surfaces.(Max13kN) 满充电电池 被两平板挤压。挤压的最大压强为17.2Mpa,最大作用力为13kN。当达到最大值即停止。	No explosion, No fire. 电池不爆炸，不起火
7.3.2 Heat Test 高温	The temperature of the baking box which contains cell is raised to 100±2°C at a rate of 5°C/min and then holded for ten minutes. 满充电电池在烘箱中测试。烘箱自室温起以5°C/min的升温速率升至100±2°C，并在100±2°C温度下保持10min。	
7.3.3 Short-Circuit Test 短路	After full charge, the positive and negative polarities are connected together by a copper wire whose resistance is less than or equal to 0.1Ω. 满充电电池用电阻不大于0.1Ω的铜导线连接其正负极至电池体温度接近室温。	No explosion, No fire 电池不爆炸，不起火
7.3.4 Over-charge Test 过充	The cell is overcharged to 4.6V with a current of 1C and holded for 48 hours. 电池在1C恒流恒压下过充至4.6V，并保持48小时	

8. Standard environmental test condition/测试条件

Unless otherwise specified, all tests stated in this Product Specification are conducted at below

Temperature: 25±2℃

Relative humidity : 65±20%

除特别说明外，本规格书中所有测试均在以下环境中进行。

温度：25±2℃ 相对湿度：65±20%

9. Charging/充电

Charging current and charging voltage should be less than specified in the Product Specification.

The charger shall be designed to comply with Product Specification.

It is dangerous that charging with higher current or voltage than Product Specification may cause damage to the cell electrical, mechanical safety performance.

充电电流和充电电压不得超出本规格书中所规定的最大值。

充电器的设计应满足本规格书的要求。

使用超出本规格书要求的电流和电压范围可能引起电芯充放电性能、机械性能和安全性能的问题。

10. warranty/品质保证

Period of warranty: 12 months after sales;

产品保质期: 自交货期开始算起后的12个月;

Range of warranty: There is low voltage, expansion or leakage with the correct use of the cell in the period of warranty.

保质范围: 正常使用或存放条件下电池有气鼓、无电压、漏液不良现象。

不当使用或存放造成电池不良不在保质范围内。

11. Liability/产品责任

Please use the Lithium-ion Polymer rechargeable cells supplied by us under the product specification .It may cause fire or expansion if the cells are used incorrect .We will not guarantee the safety unless the cells are used under the product specification.

请客户务必按照所提供的规格说明书和所附的注意事项来使用深圳市佳力能电子有限公司生产的电池。不正确使用电池，可能会导致电池性能异常、发热、着火或破裂现象。对于客户在超出规格说明书以外的情况下使用电池，佛山兆能电池实业有限公司不保证其使用性能和安全性能。

12. Identification/成品电池块（组）上标识

Warnings would better be marked on the surface of the battery which is tied up by certain cells:

*Using the charger designated by the manufacturer.

*Don't throw the battery in fire or heat it .

*Don't short-circuit .

*Don't unpack the battery or change its structure.

对用于制作电池块（组），请在电池块（组）上标记以下警告：

*使用（制造厂商）指定的充电器。

*禁止将电池投入火中或对电池加热。

*禁止将电池正负极短路。

*禁止拆开，改变电池（组）结构。

13. Notice for Designing Battery Pack / 电池块设计注意事项

13.1 Battery Pack design

电池块设计

13.1.1 Battery shell should be with enough mechanical strength, to protect the inner cell from mechanical shock;

电池外壳应有足够的机械强度以保证其内部电芯免受机械撞击;

13.1.2 No cell movement in the battery pack should be allowed;

电芯不得在壳内活动;

13.1.3 No Sharp edge or bulge components should be inside the pack containing the battery;

外壳内安装电芯的部位不应有锋利的边角或凸起;

13.2 Avoid some components to contact the edge of packing foil of batteries ;

避免导电元件与电芯包装铝箔的边缘接触;

13.3 Tab connection

电芯的连接

13.3.1 Ultrasonic welding or spot welding is recommended to connect battery with PCM or other parts;

建议使用超声波焊接或点焊技术来连接电芯与保护电路模块或其它部分;

13.3.2 The tab is not very firm. Don't bend the tab. especially the positive pole. It will rupture

电池极耳的机械强度并非十分坚固,弯折容易断裂,尤其是正极耳.禁止多次弯折极耳;

13.3.3 If apply manual solder method to connect tab with PCM, below notice is very important to ensure battery performance:

如使用手工锡焊,须注意以下事项,以保证电芯的功能:

1). The solder iron should be temperature controlled and ESD safe;

烙铁的温度可控且防静电;

2). Soldering temperature should below 350°C;

烙铁温度应该在 325-380°C;

3). Soldering time should not be longer than 3s ;

锡焊时间不能超过 3 秒;

4). Soldering times should not exceed 3 times ,secondary welding should be done after the poles are cooling;

锡焊次数不能超过 3 次,必须在极耳冷却后再进行二次焊接;

5). Directly heat cell body is strictly prohibited;

禁止直接加热电芯,高于 100°C会导致电芯损坏;

6). Don't let the electric iron contact the surface of the cell.

禁止电烙铁头接触电池表面。

Please use the battery according to the provisions as below ,Incorrect using of the battery may cause fire or expansion,and destroy its performance.

请仔细阅读并遵照以下条款安装使用电池，不正确的使用可能会导致电池气鼓、着火等，降低了电池的性能或破坏电池。

14.Warnings 警告

14.1 Don't throw the cell in fire or heat it or store it in high temperature place ;

请勿将电池放入火中，或对电池加热，请勿在高温下储存电池；

14.2 Don't operate or use the cell under high temperature or next to the heating material. Don't throw the cell in fire or heat it;

禁止在高温环境下或热源旁操作或者使用电池,禁止将电池加热或者投入火中；

14.3. Don't fix the positive and negative of the cell reversely to the electrical equipment ;

安装电池时请勿将正负极反接；

14.4 Don't connect the positive and negative polarities by metallic conductor such as a metallic wire;

请勿将电池正负极用金属物体（如导线）直接连接等方式造成电池短路；

14.5 Don't impact or scrape the surface of the cell by spiculate parts;

禁止用尖锐部件碰撞或刮擦电池表面；

14.6 Don't stab it with a needle,beating,treading,fold or other way;

请勿用针刺、用锤敲打、用力踩踏、弯折或其它方式对电池进行撞击；

14.7 Don't drop or fling the cell randomly;

禁止坠落、抛掷电池；

14.8 Keep the cell sealed!(Don't open or deform folding edge,Don't bend or fold sealing edge,etc);

请勿破坏电池密封(包括打开折边、弯折封边等)；

14.9 Don't unpack the battery or change its structure!;

请勿乱拆电池，请勿随意改变电池结构；

14.1 Don't throw the cell in water,please keep it from humidity.

请勿将电池放入水中，储存时注意电池不要受潮。

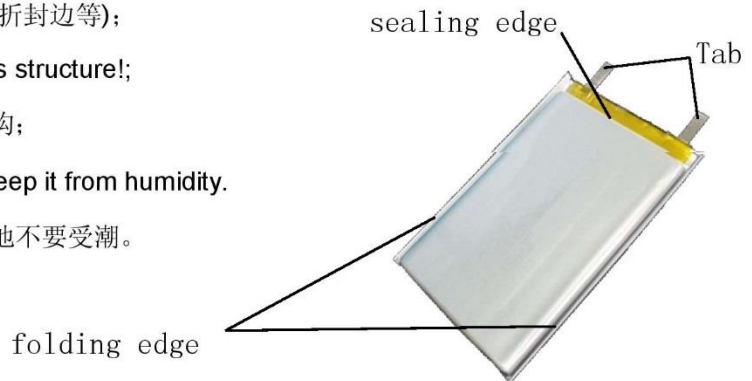

15.Attention注意

- 15.1 Please use the qualified equipment for charging and recharging the cell;
充放电时请勿用不合格设备，并遵循正确的使用说明；
- 15.2 Don't use different type of cells supplied by different manufacturer together;
请勿将不同厂家或不同种类、型号的电池以及新旧电池混用；
- 15.3 Don't charge the heating or modification cell;
请勿将发热、气鼓、变形或漏液电池放入设备中充放电；
- 15.4 Don't let the cell over-discharge.
在充放电时，不能超出本规格书规定的电压、电流范围。

16.1Reminding提醒

- 16.1 Don't use the damaged cells (the sealing edge was damaged, the pack was damaged, the electrolyte leakage etc.). If the cell heating when using, go far away from the cell, it may avoid unnecessary damage;
禁止使用已损坏的电芯(电芯封口封边损坏,外壳破损,闻到电解液,电解液泄漏等). 操作电池时,如果发现电池发热,要立即远离该电池以免造成不必要的伤害；
- 16.2 Theoretically, there is not flowing electrolyte in the cell, but if the leakage of electrolyte happen,or the electrolyte splash down to the skin, eyes or other parts of the body, wash with water and go to hospital immediately;
聚合物锂离子电池理论上不存在流动的电解液,但万一有电解液泄漏而接触到皮肤、眼睛或身体其它部位应立即用清水冲洗并就医；
- 16.3 The cells supplied by . had passed the QC before sales,If there is any abnormal problem such as unidentified heating,expansion and peculiar smell,please contact with us;
- 16.4 The Pack stored beyond half year should be charged to 3.7~3.9V/cell with constant current at 0.5C .
电池储存超过半年，请客户对电池用0.5C电流充电至单个电池电压3.7~3.9V。